

Koyo

Indice

RODAMIENTOS DE BOLAS DE LA SERIE 83000 (INCLUYE 83A000, 83B000, 83C000)



Rodamientos de bolas de la serie 83000 (incluye 83A000, 83B000, 83C000)

Los rodamientos de bolas de la serie 83000 de **Koyo** (incluye: 83A000, 83B000, 83C000) son fabricados tomándose como base de diseño, los tipos estándares de los rodamientos rígidos de bolas de 1 ó 2 hileras (series 6000, 6200, 6300, 6900, RLS..., RMS..., 4200, 4300), de los rodamientos de bolas con contacto angular de 1 ó 2 hileras (series 70000, 7200, 7300, 5200, 5300, 3200, 3300) o de rodamientos de bolas axiales (serie 51000, etc.), pero con modificaciones en sus dimensiones principales, biseles, tratamientos térmicos, sellos, etc.

El sistema de designación de esta serie es particular **Koyo** y se inicia con la combinación de números y letras: 83..., 83A..., 83B..., 83C..., como numeración básica seguida de sufijos adicionales (letras y números que informan sobre las especialidades que presentan). En este grupo hemos contenido las series 880000, RW000.

A diferencia de la mayoría de las normas de designación que rigen para los rodamientos, el número básico no guarda relación con las dimensiones principales del rodamiento y sólo representan un número consecutivo de aparición. Aplicaciones comunes: ruedas, tensores, motor fuera de borda, transmisión, etc.

Ejemplos:

| | | |
|-------------|------------------------------|---|
| 83423DB | Rueda delantera -Nissan- | Diseño básico: rodamiento de la serie 7200 (chanfle especial en anillo interno) |
| 83427 | Motor fuera de borda-Yamaha- | Diseño básico: rodamiento de la serie 5200 (jaula especial, ranura en anillo externo) |
| 83A174SH2C3 | Transmisión -Toyota- | Diseño básico: rodamiento de la serie 6300 (biseles mayores, ranura en anillo ext., tratam. térmico en aro interno) |

Los cambios más recurrentes en los diseños de rodamientos básicos son: el aro externo extendido, más ancho, con perfil especial, con pasador, con ranura, etc. En el aro int. más grueso, radio de chanfle distinto, sello metálico, sello reforzado.

▶ RODAMIENTOS AUTOMOTRICES

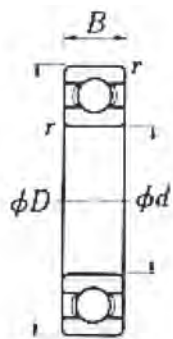

(abierto)

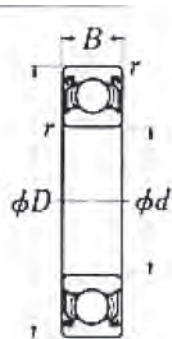

(obturados - sellados)



(con ranura - anillo elástico)

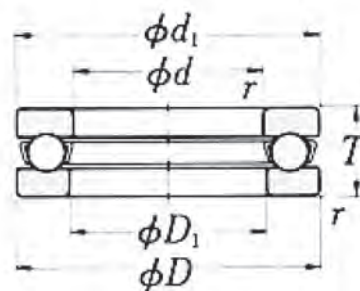

(simple efecto)

Rodamientos rígidos de bolas

Rodamientos axiales de bolas

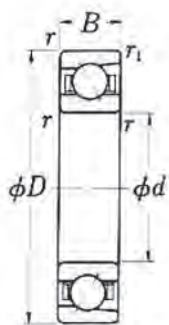

(una hilera)

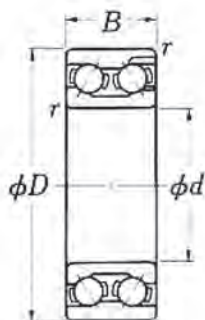



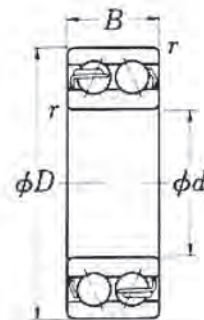











(doble hilera, serie 32...,33...)















(doble hilera, serie 52...,53...)











Rodamientos de bolas con contacto angular





| Rodamientos de bolas (rígidos, contacto angular, etc.) -series 83XXX, 83A..., 83B..., 83C... 88XXX | | | | | | | | | | |
|--|---|-------------------------|-----------------|------------------------------|-------------------------------------|------------|----------------------|-----------------|-----------------|---|
| Designación | Foto | Número de parte (O.E.M) | Fabricante | Aplicación | Dimensiones principales (unidad:mm) | | | | | Observación |
| | | | | | d diám.a.i | D Diám.a.e | B ancho ttl. o mayor | Bi ancho aro i. | Be ancho aro e. | |
| Serie 83000 | | | | | | | | | | |
| 83044 | | 195507MI | MASSEY FERGUSON | TRACTOR | 55.00 | 100.00 | 21.00 | 21.00 | 21.00 | Descontinuado |
| 83044CS | | 195507MI | MASSEY FERGUSON | TRACTOR | 55.00 | 100.00 | 21.00 | 21.00 | 21.00 | Descontinuado |
| 83064C3 | | 9-00090-164-0 | ISUZU | N/D | 16.00 | 40.00 | 12.00 | 12.00 | 12.00 | Descontinuado |
| 83085 |  | N/D | FORD | Caja de cambio | 55.00 | 100.00 | 21.00 | 21.00 | 21.00 | 6211 con jgo.int.esp.y bolas + grandes. |
| 83111C3 | | 76181-30340-71A | KOMATSU | Mástil-MONTACARGA | 40.00 | 100.00 | 30.00 | 23.00 | 30.00 | Venta exclusiva |
| 83111C3 | | N/D | TOYOTA | Mástil-MONTACARGA | 40.00 | 100.00 | 30.00 | 23.00 | 30.00 | Venta exclusiva |
| 83179YRE2C3 |  | 1-09800-087(8) | ISUZU | N/D | 60.00 | 110.00 | 22.00 | 22.00 | 22.00 | • |
| 83210BC3 |  | N/D | DANA-Spicer | Transmisión manual | 40.00 | 90.00 | 20.00 | 20.00 | 20.00 | Base:6308N. sin anillo (a.e) y abierto. |
| 83270 | | 81804635 | NEW HOLLAND | TRACTOR | 65.00 | 100.00 | 18.00 | 18.00 | 18.00 | Basado en 6013. |
| 83270 | | N/D | FORD | TRACTOR | 65.00 | 100.00 | 18.00 | 18.00 | 18.00 | Basado en 6013. |
| 83294C4 |  | 43215-18000 | NISSAN | RUEDA TRAS. | 32.00 | 62.00 | 16.00 | 16.00 | 16.00 | • |
| 83294C4 |  | 43210-21000 | NISSAN | RUEDA TRAS. | 32.00 | 62.00 | 16.00 | 16.00 | 16.00 | • |
| 83299SH2-9RTC4 |  | 93306-20438 | YAMAHA (YZ80) | Cigüeñal (D) motocicleta | 20.00 | 47.00 | 14.00 | 14.00 | 14.00 | • |
| 83357A-9C4 | | 09269-25013 | SUZUKI | Cigüeñal motocicleta | 25.00 | 62.00 | • | 17.00 | • | • |
| 83404-9C3 |  | 93306-20604 | YAMAHA | Cigüeñal motor fuera borda | 30.00 | 62.00 | 16.00 | 16.00 | 16.00 | Descontinuado |
| 83406-9TC4 | | 93306-30549 | YAMAHA | Cigüeñal motocicleta | 25.00 | 62.00 | 17.00 | 17.00 | 17.00 | Basado en 6305N-9 |
| 83406E1-9C3 | | 93306-30531 | YAMAHA | Cigüeñal motor comb. int. | 25.00 | 62.00 | 17.00 | 17.00 | 17.00 | Descontinuado |
| 83427 |  | 93305-20502 | YAMAHA | Transmisión motor comb. int. | 25.00 | 52.00 | 20.60 | 20.60 | 16.60 | • |
| 83447A-9C3 | | 09269-30006 | SUZUKI | Motor fuera /borda | 30.00 | 72.00 | 19.00 | 19.00 | 19.00 | Con buje para lubricación |
| 83464A-9TC3 |  | 93306-30510 | YAMAHA | Cigüeñal motor comb. int | 25.00 | 62.00 | 17.00 | 17.00 | 17.00 | • |
| 83464A1-9TC4 |  | N/D | YAMAHA | Cigüeñal (I) motor c.int | 25.00 | 62.00 | 17.00 | 17.00 | 17.00 | • |





| Rodamientos de bolas (rígidos, contacto angular, etc.) -series 83XXX, 83A..., 83B..., 83C... 88XXX | | | | | | | | | | | |
|--|---|-------------------------|--------------------|--------------------------|-------------------------------------|------------|----------------------|-----------------|-----------------|--|--|
| Designación | Foto | Número de parte (O.E.M) | Fabricante | Aplicación | Dimensiones principales (unidad:mm) | | | | | Observación | |
| | | | | | d diám.a.i | D Diám.a.e | B ancho ttl. o mayor | Bi ancho aro i. | Be ancho aro e. | | |
| 83464RSH2-9TCS30 | | 09262-25099 | SUZUKI (RGV. Wolf) | Cigüeñal motocicleta | 25.00 | 62.00 | 18.00 | 18.00 | 18.00 | • | |
| 83477CS23 | | 9-00090-655-0 | ISUZU | TRANSMISIÓN | 32.00 | 75.00 | 20.00 | 20.00 | 20.00 | Anillo-ranura aro ext. Escote de relleno en aros | |
| 83490 | | 9881-60109A | HINO | N/D | 60.00 | 130.00 | 31.00 | 31.00 | 31.00 | Descontinuado | |
| 83516-9TC3 | | 353-001118-0 | TOHATU | Bomba de agua | 30.00 | 72.00 | 19.00 | 19.00 | 19.00 | Pasador en aro externo | |
| 83516CSH2-9TC4 |  | 09262-30055 | SUZUKI | N/D | 30.00 | 72.00 | 19.00 | 19.00 | 19.00 | Pasador en aro externo | |
| 83522PC3 | | N/D | KOMATSU | Mastil-Montacarga | 40.00 | 109.70 | 32.00 | 23.00 | 32.00 | Rodam. base 63082RK | |
| 83522PC3 | | N/D | TOYOTA | Mastil-Montacarga | 40.00 | 109.70 | 32.00 | 23.00 | 32.00 | Rodam. base 63082RK | |
| 83526D-9C3 | | 09269-35006 | SUZUKI | N/D | 35.00 | 80.00 | 21.00 | 21.00 | 21.00 | • | |
| 83543KC3 | | N/D | KOMATSU | MONTACARGA | 35.00 | 94.50 | 28.00 | 21.00 | 28.00 | Venta exclusiva | |
| 83544KC3 | | N/D | KOMATSU | MONTACARGA | 35.00 | 114.50 | 28.00 | 21.00 | 28.00 | Aro externo más ancho. grueso. obturado. | |
| 83546-9C3 | | 09262-25030 | SUZUKI (GT) | Cigüeñal motor c.i. | 25.00 | 52.00 | 15.00 | 15.00 | 15.00 | • | |
| 83546SH2C3 | | 93306-20575 | YAMAHA | Transmisión/ Motocicleta | 25.00 | 52.00 | 15.00 | 15.00 | 15.00 | Descontinuado | |
| 83549C3 |  | C5NN-N779-B | FORD | EJE PILOTO | 36.51 | 68.00 | 15.00 | 15.00 | 15.00 | • | |
| 83553ASH2-9RCS20 | | 09262-35001 | SUZUKI | Cigüeñal de motor c.i. | 35.00 | 72.00 | 17.00 | 17.00 | 17.00 | Descontinuado | |
| 83580AC3 |  | 09262-25050 | SUZUKI | Transmisión/ Motocicleta | 25.00 | 62.00 | 17.00 | 17.00 | 17.00 | • | |
| 83580ASH2CS23 |  | 09262-25105 | SUZUKI | Transmisión/ Motocicleta | 25.00 | 62.00 | 17.00 | 17.00 | 17.00 | • | |
| 83580C-9CS30 | | 09262-25097 | SUZUKI | Cigüeñal /Motocicleta | 25.00 | 62.00 | 17.00 | 17.00 | 17.00 | • | |
| 83624C3 |  | N/D | CLARK | MONTACARGA | 45.00 | 100.00 | 21.00 | 21.00 | 21.00 | Ranura. anillo en aro ext. | |
| 83676+CAP | | 1494152 MI | MASSEY FERGUSON | N/D | 61.91 | 110.00 | 61.90 | 61.90 | 22.00 | Descontinuado | |

| Rodamientos de bolas (rígidos, contacto angular, etc.) -series 83XXX, 83A..., 83B..., 83C... 88XXX | | | | | | | | | | |
|--|---|-------------------------|--------------|--|-------------------------------------|------------|----------------------|-----------------|-----------------|---|
| Designación | Foto | Número de parte (O.E.M) | Fabricante | Aplicación | Dimensiones principales (unidad:mm) | | | | | Observación |
| | | | | | d diám.a.i | D Diám.a.e | B ancho ttl. o mayor | Bi ancho aro i. | Be ancho aro e. | |
| 83746ASH4-9TC3 | | 93306-206-U3 | YAMAHA | Cigüeñal/Motor fuera borda | 30.00 | 66.00 | • | 16.00 | • | Venta exclusiva |
| 83763-1SH2C4 | | N/D | DANA Spicer | TRANSM.MANUAL | 40.00 | 90.00 | 23.00 | 23.00 | 23.00 | Descontinuado |
| 83763-1SH2C4 | | N/D | FORD | TRANSM.MANUAL | 40.00 | 90.00 | 23.00 | 23.00 | 23.00 | Descontinuado |
| 83765C3 | | MD800764 | MITSUBISHI | N/D | 42.00 | 85.00 | • | 19.00 | • | Descontinuado |
| 83805C3 |  | 949100-1610 | NIPPON DENSO | Sist.aire/acondicionado | 12.50 | 32.00 | 10.00 | 10.00 | 10.00 | Obturado. Chanfle r=1.0 mm |
| 83805FC2 | | 949100-1610 | NIPPON DENSO | Sist.aire/acondicionado | 12.50 | 32.00 | 10.00 | 10.00 | 10.00 | Descontinuado |
| 83913-9TC4 | | 93306-30615 | YAMAHA | Cigüeñal motor c. int. (motocicleta, motor a popa) | 30.00 | 72.00 | 19.00 | 19.00 | 19.00 | Rodamiento abierto. Chanfle: 1.1. 2 mm |
| 83943CSH2C3 |  | 09262-22017 | SUZUKI | Transmisión/ Motocicleta | 22.00 | 56.00 | • | 16.00 | • | Tratamiento térmico en aro int. |
| 83993SH2CS6 | | 92045-035 | KAWASAKI | Transmisión / Motocicleta | 25.00 | 52.00 | • | 20.60 | • | • |
| Serie 83A000 | | | | | | | | | | |
| 83A066PBSCS59 | | 59117-1200 | NISSAN | MONTACARGA | 45.00 | 115.00 | 31.50 | 25.00 | 31.50 | Aro externo más ancho. grueso. |
| 83A066PBSCS59 | | 912362 | JEEP WILLY | EJE DE TOMA | 45.00 | 115.00 | 31.50 | 25.00 | 31.50 | Aro externo más ancho. grueso. |
| 83A070SH4CS26 | | 93304-205U0 | YAMAHA | MOT.FUERA/BORDA | 25.00 | 57.00 | 18.00 | 18.00 | 18.00 | Rodamiento rígido -2 hileras. pasador en a.e. |
| 83A093-9TC4 | | 93306-20627 | YAMAHA | Cigüeñal /Motocicleta | 30.00 | 62.00 | 16.00 | 16.00 | 16.00 | Rodam. abierto (radio a.i =2.5mm) |
| 83A105BCS17 |  | 09262-14001 | DAEWOO | SUSPENSIÓN | 14.05 | 42.00 | 16.00 | 16.00 | 11.00 | Rodamiento abierto |
| 83A105BCS17 |  | N/D | OPEL | SUSPENSIÓN | 14.05 | 42.00 | 16.00 | 16.00 | 11.00 | Rodamiento abierto |
| 83A105BCS17 |  | 90105091 | GM | N/D | 14.05 | 42.00 | 16.00 | 16.00 | 11.00 | Rodamiento abierto |
| 83A167NBC3 | | 3ED7141210 | KOMATSU | MONTACARGA | 55.00 | 139.40 | 45.00 | 29.00 | 45.00 | Obturado. con aro ext. más ancho. |
| 83A170C4 |  | 5-09801-001-0 | ISUZU | PIÑÓN FRONTAL | 16.00 | 40.00 | 12.00 | 12.00 | 12.00 | Chanfles r=1.0mm |
| 83A174ASH2C3 |  | 90363-25029 | TOYOTA | TRANSMISIÓN | 25.00 | 62.00 | 17.00 | 17.00 | 17.00 | Ranura en aro externo |

| Rodamientos de bolas (rígidos, contacto angular, etc.) -series 83XXX, 83A..., 83B..., 83C... 88XXX | | | | | | | | | | | |
|--|---|-------------------------|------------|----------------------------|-------------------------------------|------------|----------------------|-----------------|-----------------|--|--|
| Designación | Foto | Número de parte (O.E.M) | Fabricante | Aplicación | Dimensiones principales (unidad:mm) | | | | | Observación | |
| | | | | | d diám.a.i | D Diám.a.e | B ancho ttl. o mayor | Bi ancho aro i. | Be ancho aro e. | | |
| 83A209D-9TC3 | | 93306-306U2 | YAMAHA | Cigüeñal/Motor fuera borda | 30.00 | 72.00 | 19.00 | 19.00 | 19.00 | Pasador en aro externo | |
| 83A263SH4-9TC3 | | 93306-206U5 | YAMAHA | Cigüeñal/Motor fuera borda | 32.00 | 66.00 | 16.00 | 16.00 | 16.00 | Chanfle= 1.5 mm ext. | |
| 83A367CPT4SH2-9C3 | | 09262-30048 | SUZUKI | MOTOCICLETA | 30.00 | 72.00 | 19.00 | 19.00 | 19.00 | Ranura, pasador en aro externo | |
| 83A400C3 |  | 90363-32006 | TOYOTA | Caja de transferencia | 32.00 | 75.00 | 20.00 | 20.00 | 20.00 | Rodam.básico 63/32. Ranura aro ext. | |
| 83A460CCS45 |  | 8-94220-590 | ISUZU | Caja de transferencia | 25.00 | 52.00 | 23.60 | 23.60 | 23.60 | Antes 83A460ACS21. Contacto ang. de 2 hileras, sin ranura aro ext. | |
| 83A504SH2C3 |  | 90363-20075 | TOYOTA | TRANSMISIÓN | 20.00 | 57.15 | 17.46 | 17.46 | 17.46 | Chanfle a.e.=2.0mm, Chanfle a.i.=0.4mm | |
| 83A551BCS45 | | 8536-1020 | MAZDA | AIRE ACOND. | 40.00 | 62.00 | 24.00 | 24.00 | 24.00 | Rodam. bolas contacto ang. 2 hil, chanfles =1.2mm | |
| 83A693CS30 |  | N/D | SANDEN | Aire acondicionado | 30.00 | 47.00 | 18.00 | 18.00 | 18.00 | Sello en ambos lados. (Rodamiento base 6906 2RU) | |
| 83A693CS30 |  | N/D | DAIHATSU | Aire acondicionado | 30.00 | 47.00 | 18.00 | 18.00 | 18.00 | Sello en ambos lados. (Rodamiento base 6906 2RU) | |
| 83A693CS30 |  | N/D | SUZUKI | Aire acondicionado | 30.00 | 47.00 | 18.00 | 18.00 | 18.00 | Sello en ambos lados. (Rodamiento base 6906 2RU) | |
| 83A694CS30 | | 85430020 | SANDEN | Sistema Aire acond. | 35.00 | 55.00 | 20.00 | 20.00 | 20.00 | Cambio a DAC35552RD3XS1CS33 | |
| 83A733C3 | | 90363-19004 | TOYOTA | DIFERENCIAL | 19.00 | 33.00 | 7.00 | 7.00 | 7.00 | Rodam. base 6804 | |
| 83A735 | | 93306-36401 | YAMAHA | Transmisión/ Motocicleta | 28.00 | 68.00 | 18.00 | 12.00 | 18.00 | Ranura, anillo y pasador en aro ext. | |
| 83A825FSH2-9CS23 | | 93306-306-V2 | YAMAHA | Motor fuera /borda | 30.00 | 72.00 | 21.50 | 19.00 | 21.50 | Aro ext. Extendido ranura, pasador. | |

| Rodamientos de bolas (rígidos, contacto angular, etc.) -series 83XXX, 83A..., 83B..., 83C... 88XXX | | | | | | | | | | |
|--|---|-------------------------|-----------------|----------------------------|-------------------------------------|------------|----------------------|-----------------|-----------------|---|
| Designación | Foto | Número de parte (O.E.M) | Fabricante | Aplicación | Dimensiones principales (unidad:mm) | | | | | Observación |
| | | | | | d diám.a.i | D Diám.a.e | B ancho ttl. o mayor | Bi ancho aro i. | Be ancho aro e. | |
| 83A831GC5 |  | 90369-36001 | TOYOTA | J-. Homocinética | 36.20 | 67.00 | 23.00 | 23.00 | 23.00 | Placa metálica (ambos lados) |
| 83A831GCS53 |  | 90363-36001 | TOYOTA | RUEDAS | 36.20 | 67.00 | 23.00 | 23.00 | 23.00 | Placa metálica y sello |
| 83A831GCS53 |  | 27831-63B00 | SUZUKI | RUEDAS | 36.20 | 67.00 | 23.00 | 23.00 | 23.00 | Placa metálica y sello |
| 83A831SC5 |  | N/D | SUZUKI (Baleno) | Rodam. central (Cardán) | 36.20 | 67.00 | 18.40 | 18.40 | 18.40 | Rodamiento obturado |
| 83A831UCS29 | | N/D | TOYOTA | DRIVE SHAFT | 36.20 | 67.00 | 23.00 | 23.00 | 23.00 | • |
| 83A839AVCS62 |  | 9139873-01 | KOMATSU | Montacarga | 60.00 | 126.00 | 31.00 | 31.00 | 22.00 | Basado en M6212ZZX |
| 83A843SH4-9TC4 | | 09262-30065 | SUZUKI | Cigüeñal/Motor fuera borda | 30.00 | 72.00 | 23.00 | 19.00 | 23.00 | Descontinuado |
| 83A844ASH2-9TC4 |  | 09262-35049 | SUZUKI | Cigüeñal/Motor fuera borda | 35.00 | 72.00 | 17.00 | 17.00 | 17.00 | Pasador en aro externo |
| 83A898C4 | | 90363-35020 | TOYOTA | CAJA TRANSFER. | 35.20 | 80.00 | 21.00 | 21.00 | 21.00 | Ranura y anillo en aro ext. |
| 83A910BC3 |  | MB293314 | MITSUBISHI | Rodam. central (Cardán) | 40.00 | 72.00 | 18.00 | 18.00 | 17.00 | Rodamiento abierto |
| 83A915SH2-9TC4 |  | 93306-20562 | YAMAHA | Cigüeñal /Motocicleta | 25.00 | 55.00 | 15.00 | 15.00 | 15.00 | Chanfles=1.5mm, aro externo grueso. |
| 83A916CSH2-9TC4 |  | 93306-20577 | YAMAHA | Cigüeñal Izq-Med / Motoc. | 25.00 | 55.00 | 15.00 | 15.00 | 15.00 | Aro externo grueso, con pasador (r=1.5mm) |
| 83A941ASH2C3 |  | 90363-45010 | TOYOTA | TRANSMISIÓN | 45.00 | 100.00 | 28.00 | 28.00 | 28.00 | Obturado. Ranura en aro ext. |
| 83A947ASH2-9TCS37 | | N/D | YAMAHA | Cigüeñal/Motor fuera borda | 30.00 | 72.00 | 19.00 | 19.00 | 19.00 | Rodam. abierto Ranura, pasador en aro ext. |
| 83A947ASH2-9TCS37 | | 91004-657-0040 | HONDA | Cigüeñal/Motor fuera borda | 30.00 | 72.00 | 19.00 | 19.00 | 19.00 | Rodam. abierto Ranura, pasador en aro ext. |
| 83A983CCS5 |  | MB532489 | MITSUBISHI | SIST. DIRECCIÓN | 17.00 | 35.00 | 10.00 | 10.00 | 10.00 | Placa metálica (1 lado) aro interno grueso. |

| Rodamientos de bolas (rígidos, contacto angular, etc.) -series 83XXX, 83A..., 83B..., 83C... 88XXX | | | | | | | | | | |
|--|---|-------------------------|---------------|---------------------------|-------------------------------------|------------|----------------------|-----------------|-----------------|--------------------------------------|
| Designación | Foto | Número de parte (O.E.M) | Fabricante | Aplicación | Dimensiones principales (unidad:mm) | | | | | Observación |
| | | | | | d diám.a.i | D Diám.a.e | B ancho tti. o mayor | Bi ancho aro i. | Be ancho aro e. | |
| Serie 83B000 | | | | | | | | | | |
| 83B051DSH2-9TCS37 |  | 93306-20578 | YAMAHA | Cigüeñal/ Motocicleta | 25.00 | 55.00 | • | 15.00 | • | Venta exclusiva |
| 83B139SH2C3 | | 93306-20217 | YAMAHA | Cigüeñal/ Motocicleta | 22.00 | 50.00 | 20.60 | 20.60 | 20.60 | Descontinuado |
| 83B166 | | AR26845 | JOHN DEERE | TRACTOR | 65.00 | 100.00 | 20.64 | 18.00 | 18.00 | Placa-tapa metálica para lubricación |
| 83B169ACS63 |  | 90369-36008 | TOYOTA | DIFERENCIAL | 36.20 | 67.00 | • | 29.00 | • | • |
| 83B207-9CD3 | | 93303-30601 | YAMAHA | Motor fuera/borda | 32.00 | 72.00 | • | 30.20 | • | Venta exclusiva |
| 83B216CD3 | | 46AX541 | MACK (camión) | Bomba de agua | 20.00 | 52.00 | • | 25.40 | 25.40 | • |
| 83B218UJ4CM | | N/D | BOSCH | ALTERNADOR | 17.00 | 52.00 | 17.00 | 17.00 | 17.00 | Obturado |
| 83B231DCS29 | | 90363-41002 | TOYOTA | Eje de tracción | 41.20 | 72.00 | • | 23.00 | • | Nuevo # 83B231DCS19 |
| 83B247SH2C3 | | 93306-20576 | YAMAHA | Motocicleta | 25.00 | 52.00 | 15.00 | 15.00 | 15.00 | Descontinuado |
| 83B285SH2C3 | | 93306-637 | YAMAHA | Transmisión / Motocicleta | 22.00 | 56.00 | 16.00 | 16.00 | 16.00 | Ranura, pasador en aro ext.. |
| 83B332 |  | JD8676 | JOHN DEERE | TRACTOR | 88.90 | 127.00 | 19.05 | 19.05 | 19.05 | Rodamiento abierto |
| 83B333A-9C3 | | 93306-30550 | YAMAHA | Transmisión/ Motocicleta | 25.00 | 62.00 | 17.00 | 17.00 | 17.00 | Descontinuado |
| 83B437ABS | | 37B9AA2111 | KOMATSU | MONTACARGA | 35.00 | 107.80 | • | 31.00 | • | • |
| 83B569AASH2-9TCS39 |  | 91002-KV3-831 | HONDA | MOTOCICLETA | 28.00 | 68.00 | • | 17.00 | • | • |
| 83B572 SH2C3 | | N/D | EATON | Transmisión(eje salida) | 63.50 | 125.00 | 24.00 | 24.00 | 24.00 | Descontinuado |
| 83B607ACS8 | | AA21480 | JOHN DEERE | Rueda de plantadora | 16.03 | 45.23 | 18.67 | 18.67 | 15.49 | Descontinuado |
| 83B673 | | 91003-MN5-003 | HONDA | Transmisión/ Motocicleta | 22.00 | 56.00 | • | 16.00 | • | • |
| 83B700A | | 91004-KW3-004 | HONDA | Transmisión/ Motocicleta | 22.00 | 50.00 | • | 14.00 | • | • |
| 83B716-9RC3 | | 93306-304U0 | YAMAHA | MOT.FUERA /BORDA | 20.00 | 57.00 | • | 15.00 | • | Descontinuado |
| 83B717-9RC3 | | 93306-205U2 | YAMAHA | MOT.FUERA/BORDA | 25.00 | 57.00 | • | 15.00 | • | Descontinuado |
| 83B727-9C3 | | 93306-307-U1 | YAMAHA | MOT.FUERA/BORDA | 35.00 | 80.00 | • | 21.00 | • | Descontinuado |

| Rodamientos de bolas (rígidos, contacto angular, etc.) -series 83XXX, 83A..., 83B..., 83C... 88XXX | | | | | | | | | | |
|--|---|-------------------------|------------------------------|-----------------------------|-------------------------------------|------------|----------------------|-----------------|-----------------|--|
| Designación | Foto | Número de parte (O.E.M) | Fabricante | Aplicación | Dimensiones principales (unidad:mm) | | | | | Observación |
| | | | | | d diám.a.i | D Diám.a.e | B ancho ttl. o mayor | Bi ancho aro i. | Be ancho aro e. | |
| 83B729-9C3 | | 93306-307-U3PP00 | SANSHIN | Cigüeñal/Motor c. int. | 35.00 | 72.00 | • | 17.00 | • | Descontinuado |
| 83B729-9TC3 | | 93306-207U2 | YAMAHA | Cigüeñal/Motor fuera borda | 35.00 | 72.00 | 17.00 | 17.00 | 17.00 | Venta exclusiva |
| 83B745CSH4-9TC3 | | 93306-206U7 | YAMAHA | Cigüeñal/Motor fuera borda | 30.00 | 66.00 | • | 16.00 | • | Venta exclusiva |
| 83B763BSH2C3 | | N/D | Taxi-Carbodies(Ing.) Eje GKN | Eje trasero/rueda | 35.00 | 80.00 | 30.00 | 30.00 | 27.00 | O-ring en a.e. Aro int. extendido 1 lado |
| 83B889CS10 | | N/D | N/D | SIST. DIRECCIÓN | 18.00 | 55.00 | 18.00 | 18.00 | • | Descontinuado |
| Serie 83C000 | | | | | | | | | | |
| 83C032SH2-9TCS37 |  | 09262-30068 | SUZUKI | Cigüeñal/Motor fuera borda | 30.00 | 72.00 | • | 19.00 | • | • |
| 83C034C3 | | N/D | TOYOTA.Lucida | Amort. hidráulica | 90.00 | 117.00 | 15.00 | 15.00 | 15.00 | Descontinuado |
| 83C062DSH2 |  | 5566507 | EATON | Transmisión/eje ent. | 90.00 | 140.00 | 24.00 | 24.00 | 24.00 | Basado 6018NR |
| 83C111CS31 | | N/D | TOYOTA | STEERING GEAR | 18.72 | 28.00 | 7.00 | 7.00 | 7.00 | • |
| 83C137ESH2-9TCS39 | | 91003-KV3-951 | HONDA | MOTOCICLETA | 28.00 | 68.00 | • | 18.80 | • | • |
| 83C259BC3 | | N/D | FORD-Contour | Col.dirección (eje entrada) | 20.66 | 38.61 | 6.80 | 6.80 | 6.80 | Descontinuado |
| 83C288C2 | | 341450 | DUNLOP | SUSPENSIÓN | 14.00 | 42.00 | 16.00 | 16.00 | 11.00 | Rodamiento obturado |
| 83C399AC3 | | 1344566 | SUMITOMO | N/D | 35.00 | 91.80 | 31.00 | 20.00 | 31.00 | • |
| 83C507C3 | | 9249323-01 | SUMITOMO | MONTACARGA | 40.00 | 111.10 | 32.36 | 21.65 | 32.36 | • |
| Serie 88 00 00 | | | | | | | | | | |
| 881072RR4 |  | N/D | (Marca HIC) | RUEDA TRASERA | 35.00 | 72.00 | 25.00 | 25.00 | 17.00 | Rodamiento obturado |
| 881282RSE6CS |  | N/D | (Marca HIC) | RUEDA TRASERA | 38.89 | 80.00 | 27.50 | 27.50 | 21.00 | Descontinuado |
| 881282RSE6CS+R | | N/D | (Marca HIC) | RUEDA TRASERA | 38.89 | 80.00 | 27.50 | 27.50 | 21.00 | Descontinuado |
| 8MTH7025 | | N/D | CHEVROLET | RUEDA | 40.00 | 90.00 | 20.00 | 20.00 | 20.00 | Base 6308N sin anillo Ranura en a. ext. |
| Serie RW200 | | | | | | | | | | |
| RW207HH | | N/D | (Marca HIC) | N/D | 35.00 | 72.00 | • | 21.46 | 21.43 | Descontinuado |
| RW207HHC3+R | | N/D | (Marca HIC) | N/D | 35.00 | 72.00 | • | 21.46 | 21.43 | Descontinuado |
| RW207HHC3+R | | N/D | (Marca HIC) | N/D | 35.00 | 72.00 | • | 21.46 | 21.43 | Descontinuado |
| RW207HHC3+R1 |  | N/D | (Marca HIC) | N/D | 35.00 | 72.00 | • | 21.46 | 21.43 | • |

► RODAMIENTOS AUTOMOTRICES

SERIE 83000

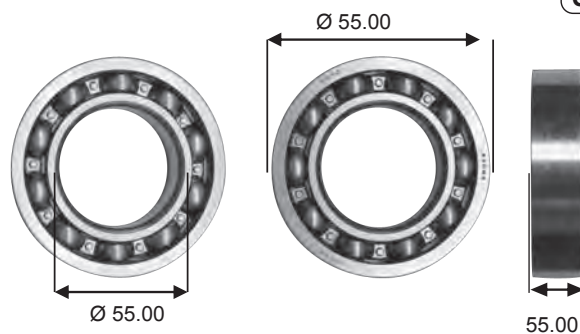

83085

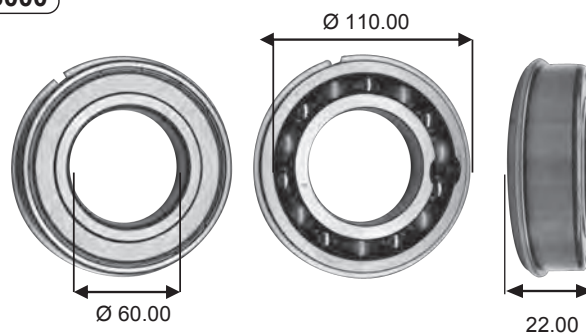

83179YRE2C3

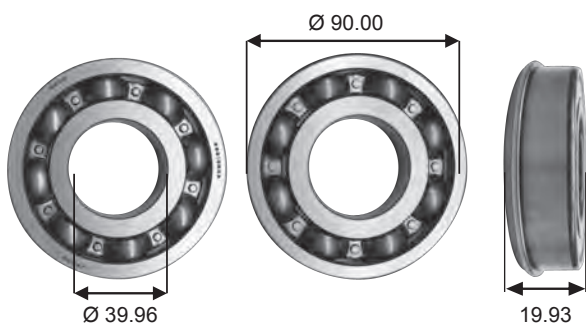

83210BC3

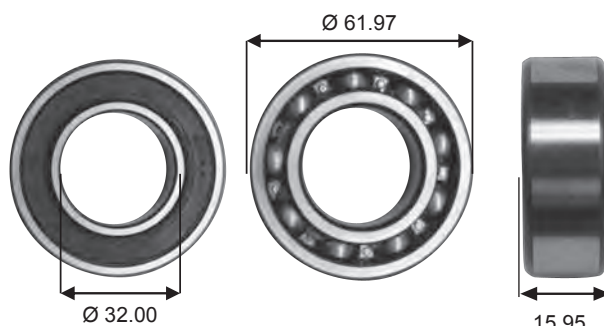

83294C4

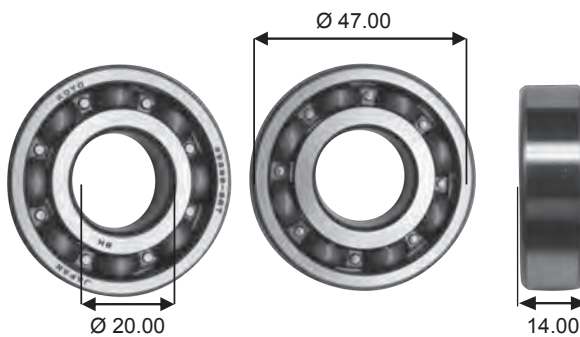

83299SH2 - 9RTC4

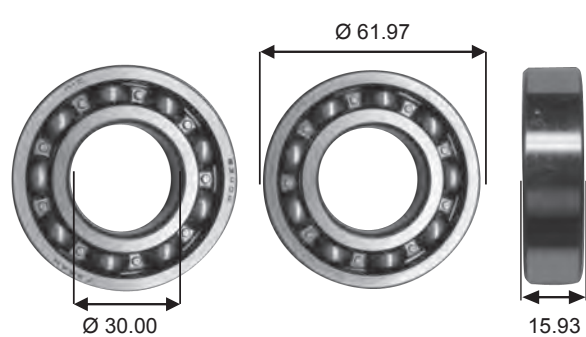

83404 - 9C3

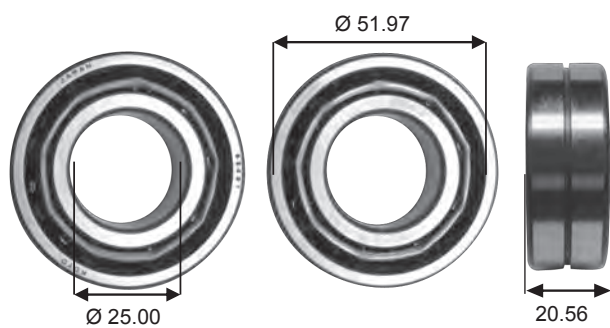

83427

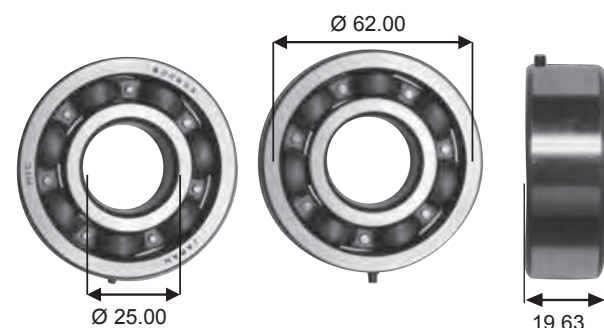

83464A - 9TC3

▶ RODAMIENTOS AUTOMOTRICES

SERIE 83000

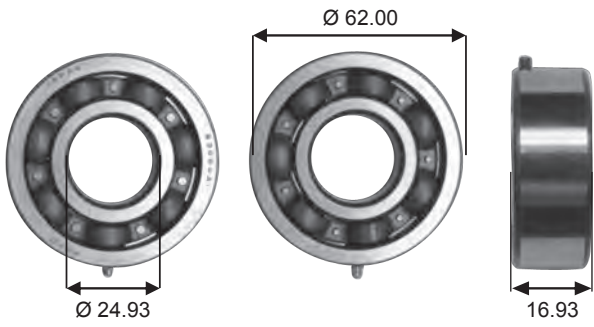

83464A1 - 9TC4

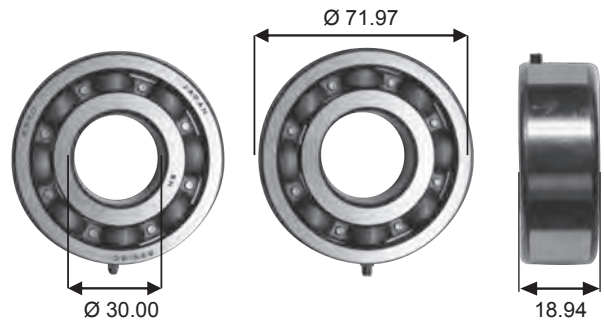

83516CSH2 - 9TC4

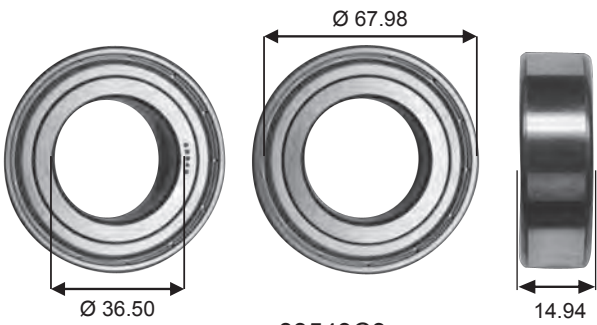

83549C3

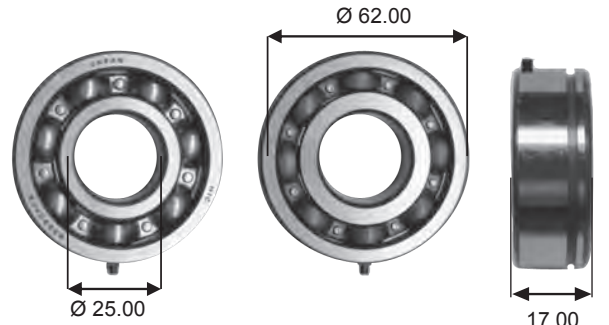

83580AC3

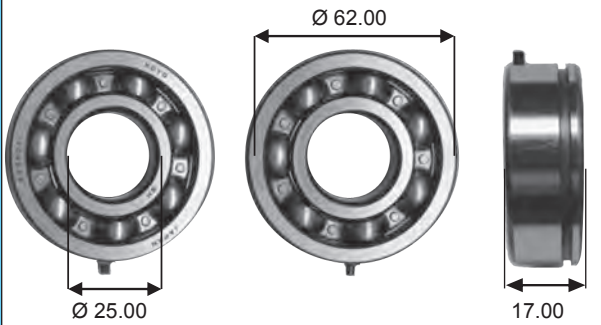

83580ASH2CS23

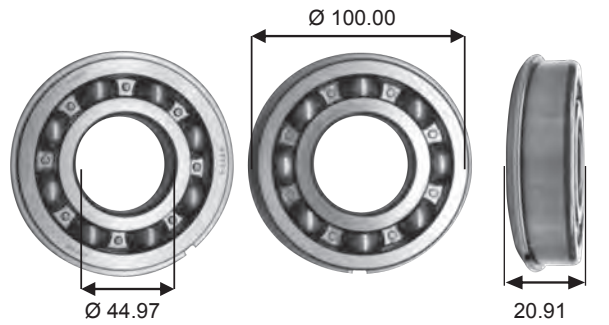

83624C3

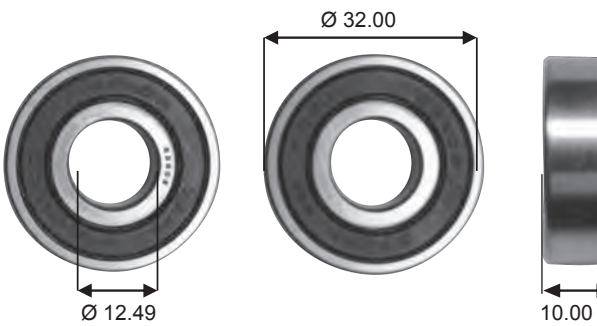

83805C3

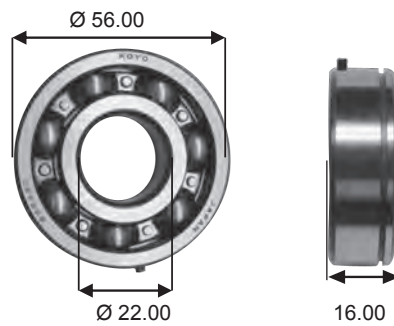

83943CSH2C3

► RODAMIENTOS AUTOMOTRICES

SERIE 83A000

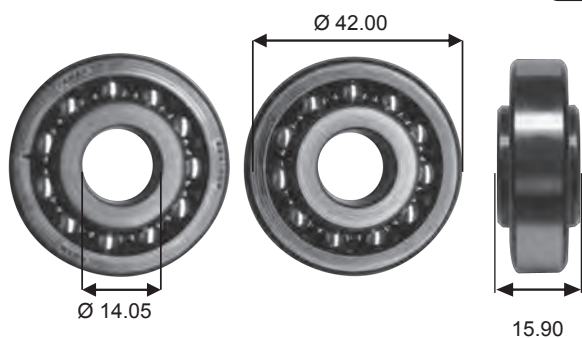

83A105BCS17

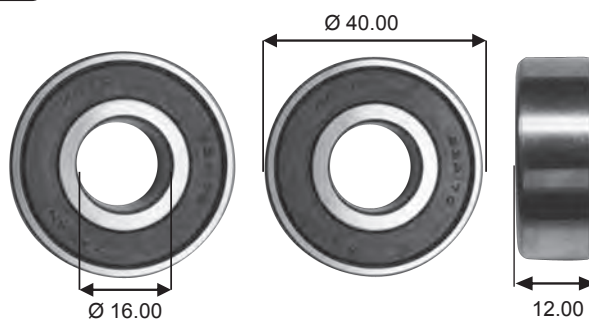

83A170C4

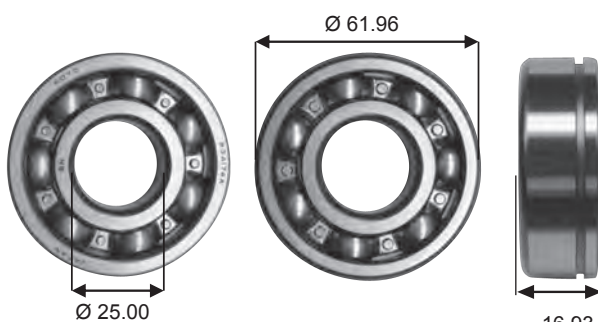

83A174ASH2C3

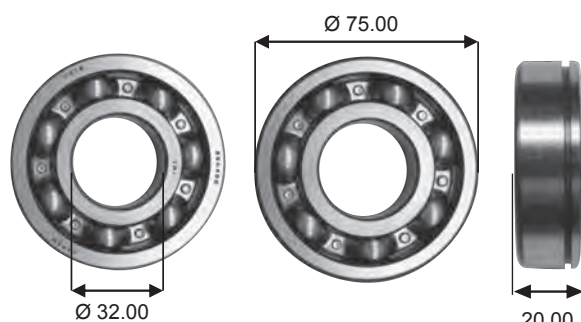

83A400C3

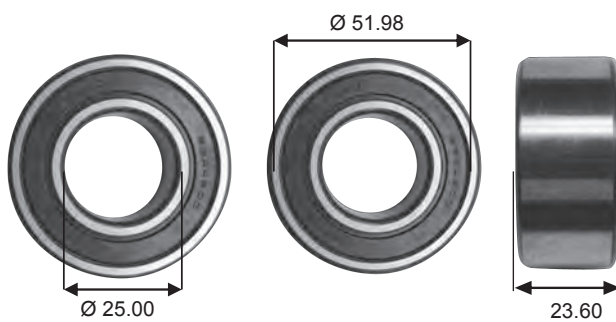

83A460CCS45

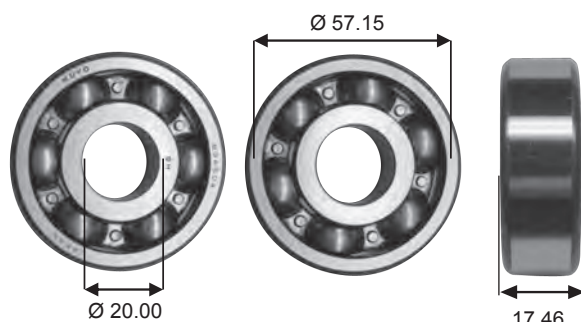

83A504SH2C3

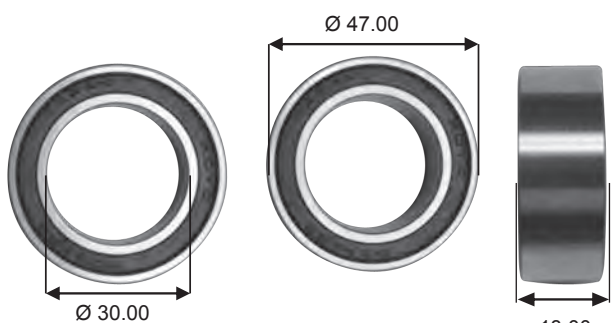

83A693CS30

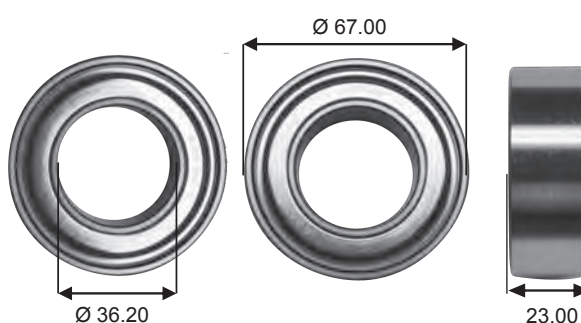

83A831GC5

SERIE 83000

▶ RODAMIENTOS AUTOMOTRICES

SERIE 83A000

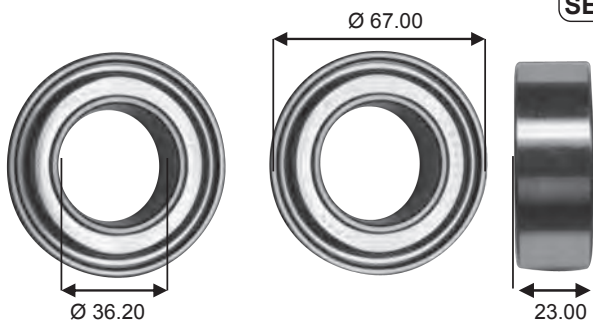

83A831GCS53

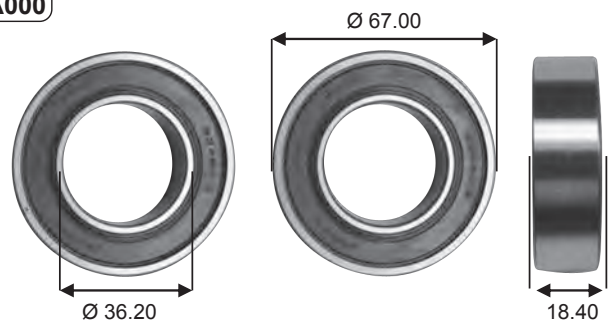

83A831SC5

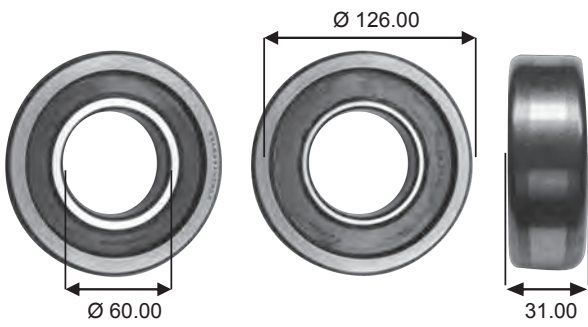

83A839AVCS62

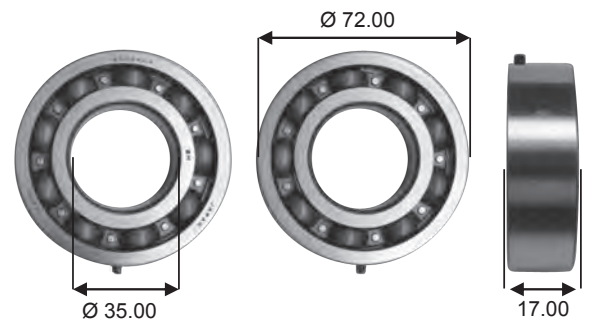

83A844ASH2 - 9TC4

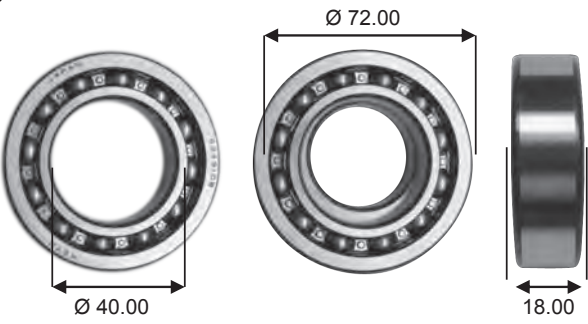

83A910BC3

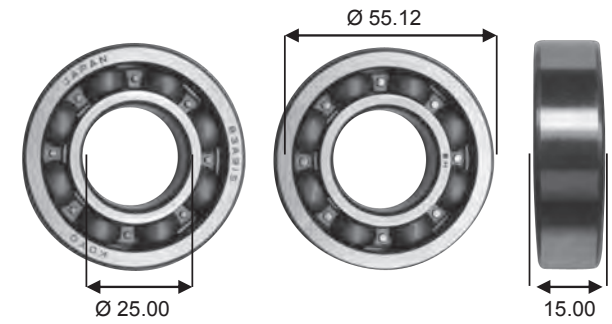

83A915SH2 - 9TC4

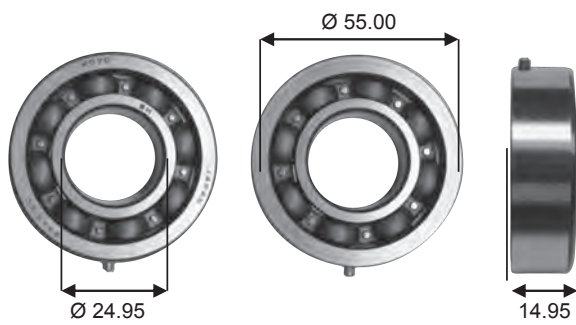

83A916CSH2 - 9TC4

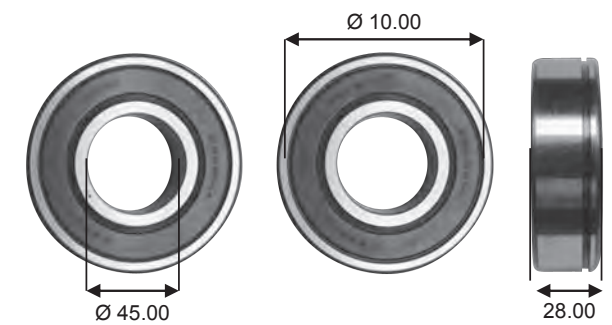

83A941ASH2C3

▶ RODAMIENTOS AUTOMOTRICES

SERIE 83A000

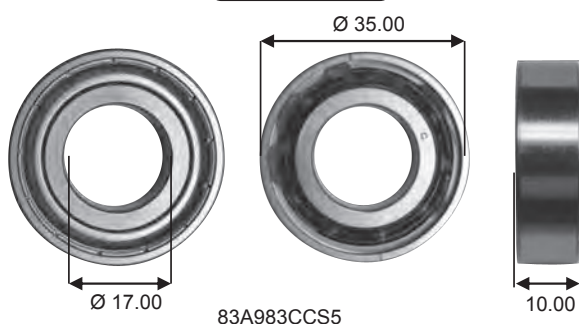

83A983CCS5

SERIE 83B000

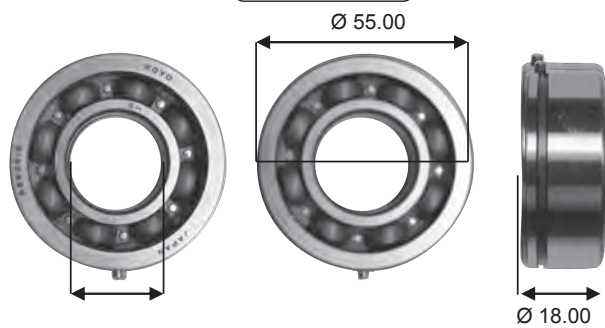

83B051DSH2 - 9TCS37

SERIE 83B000

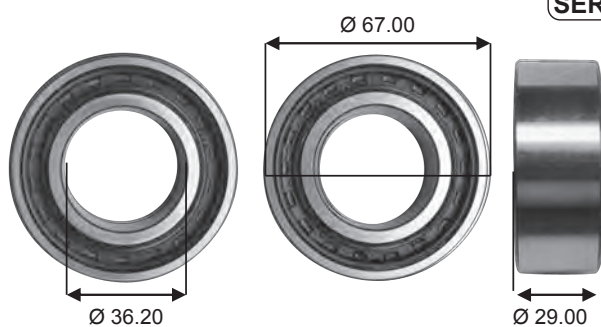

83B169ACS63

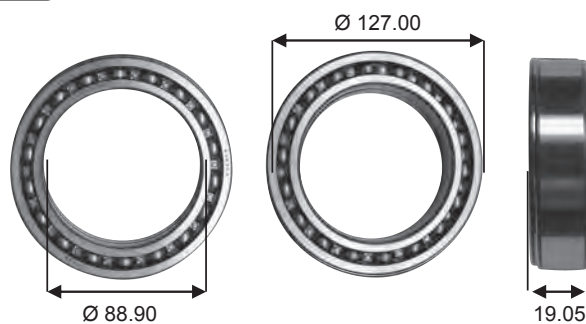

83B332

SERIE 83C000

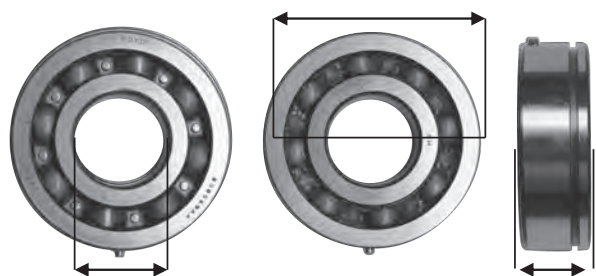

83B569AASH2 - 9TCS39

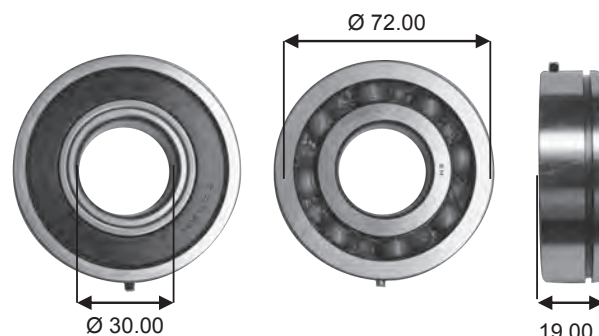

83C032SH2 - 9TCS37

SERIE 83C000

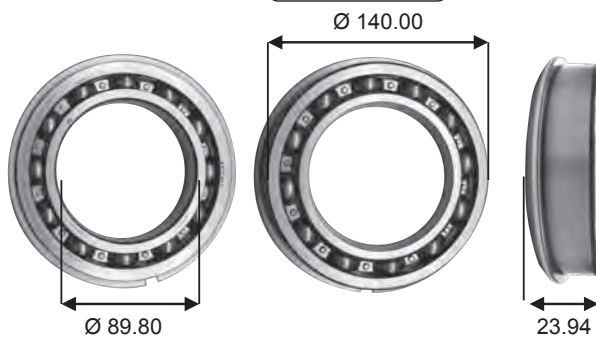

83C062DSH2

SERIE 88000

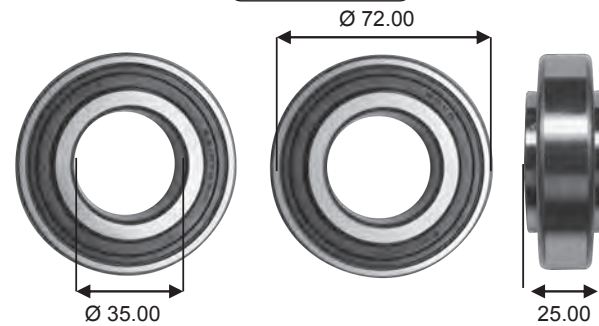

881072RR4

▶▶ RODAMIENTOS AUTOMOTRICES

